

42117

NEGATIVE HIGH TEMPERATURE FIXED VOLTAGE REGULATOR

Designed to use in high temperature environments

Mii

MICROPAC

MICROCIRCUITS PRODUCTS
DIVISION

Features:

- Operating temperature +200°C
- Output current to 1.0 A
- Input voltage to -38V
- Output voltage to -30 V
- Internal short circuit protection, foldback and current limiting
- Isolated TO-258 package

Applications:

- Down hole
- Harsh environment application

DESCRIPTION

The 42117 series of fixed voltage regulators covers the output voltage range from -5 VDC through -30 VDC. These voltage regulators are fabricated using hybrid techniques and will operate at case temperatures up to +200°C. These devices are complete with internal short circuit protection, which includes voltage shutdown and current foldback. It is strongly recommended that input and output capacitors be added as close to the case as possible. A 2µf capacitor should be added to the input and a minimum of 1.5µf capacitor should be added to the output. See typical connection diagram below.

ABSOLUTE MAXIMUM RATINGS AT 200°C CASE TEMPERATURE

Output Current (I_{OUT}).....	1.0 A
Input Voltage (V_{IN})	-38 VDC
Storage Temperature (T_{STG}).....	+250°C
Power Dissipation P_d	8 W

Typical Connection Diagram

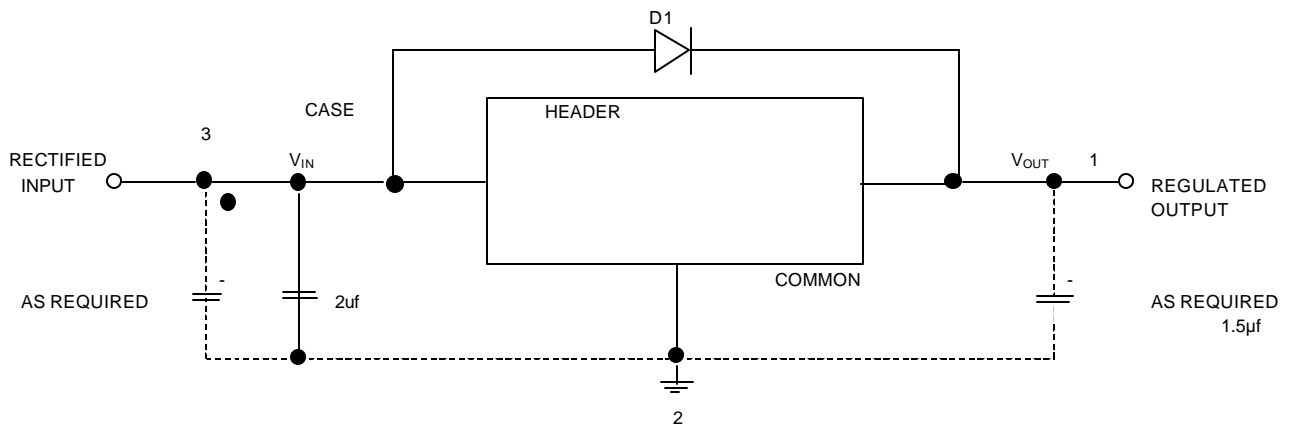

Note: D1 should be installed for input safety

Micropac Industries cannot assume any responsibility for any circuits shown or represent that they are free from patent infringement. Micropac reserves the right to make changes at any time in order to improve design and to supply the best product possible.

ELECTRICAL CHARACTERISTICS

PARAMETER	TEST CONDITIONS	TEMPERATURE	TYPICAL
*Output Voltage Note 1	$I_{OUT} = 1.0 \text{ A}$ $V_{IN} = V_{OUT} + 3 \text{ VDC}$	+25°C to +200°C	$V_{OUT} \pm 1.0\%$
*Line Regulation Note 2	$V_{IN} = V_{OUT} - 3 \text{ V}_{DC} \text{ to } -38 \text{ VDC}$ $I_{OUT} = 50 \text{ mA}$	+25°C to +200°C	$V_{OUT} \pm 0.5\%$
Load Regulation	$V_{IN} = V_{OUT} - 5 \text{ VDC}$ $I_{OUT} = 0.05 \text{ to } 1.0 \text{ A}$	+25°C to +200°C	$V_{OUT} \pm 0.5\%$ at 25°C $\pm 1.0\%$ at 200°C
Ripple Rejection at 120 Hz	$V_{IN} = V_{OUT} - 5 \text{ VDC}$ $I_L = 300 \text{ mA}$	+25°C	-50 dB
Standby Current	$V_{IN} = V_{OUT} - 5 \text{ VDC}$ $I_{OUT} = 0$	+25°C	30 mA
Short Circuit Current	$V_{IN} = V_{OUT} - 5 \text{ VDC}$	+25°C	400 mA
Short Circuit Current	$V_{IN} = V_{OUT} - 5 \text{ VDC}$	+200°C	200 mA
Foldback Current (knee)	$V_{IN} = V_{OUT} - 5 \text{ VDC}$	+25°C	2 A
Foldback Current (knee)	$V_{IN} = V_{OUT} - 5 \text{ VDC}$	+200°C	1.5 A
Noise Output	$V_{IN} = V_{OUT} - 5 \text{ VDC}$ $I_{OUT} = 300 \text{ mA}$	+25°C	2 mVRMS
Differential Voltage * ($\Delta V = V_{IN} - V_{OUT}$)	$I_{OUT} = 300 \text{ mA}$	+25°C to +200°C	3 VDC MIN

Note 1. V_{OUT} for 5 volt $\pm 2\%$

Note 2. Line regulation for 5 volt devices $\pm 1\%$

* $V_{IN} = -10 \text{ V Min}$

TABLE 1 (see note)

TYPE	V_{OUT} VDC	MAX I_{OUT} A	TYP I_{KNEE} (A at 25°C)
42117-005	-5	1.0	2.0
42117-012	-12	1.0	2.0
42117-015	-15	1.0	2.0
42117-018	-18	1.0	2.0
42117-024	-24	1.0	2.0
42117-030	-30	1.0	2.0

NOTE: Under condition ($V_{IN} - V_{OUT}$) $\times I_{OUT} \leq 8$ watts at 200°C

- Option: 1) Other output voltage available
2) MIL-STD-883 type screening available

Micropac Industries cannot assume any responsibility for any circuits shown or represent that they are free from patent infringement. Micropac reserves the right to make changes at any time in order to improve design and to supply the best product possible.

Mechanical Configuration

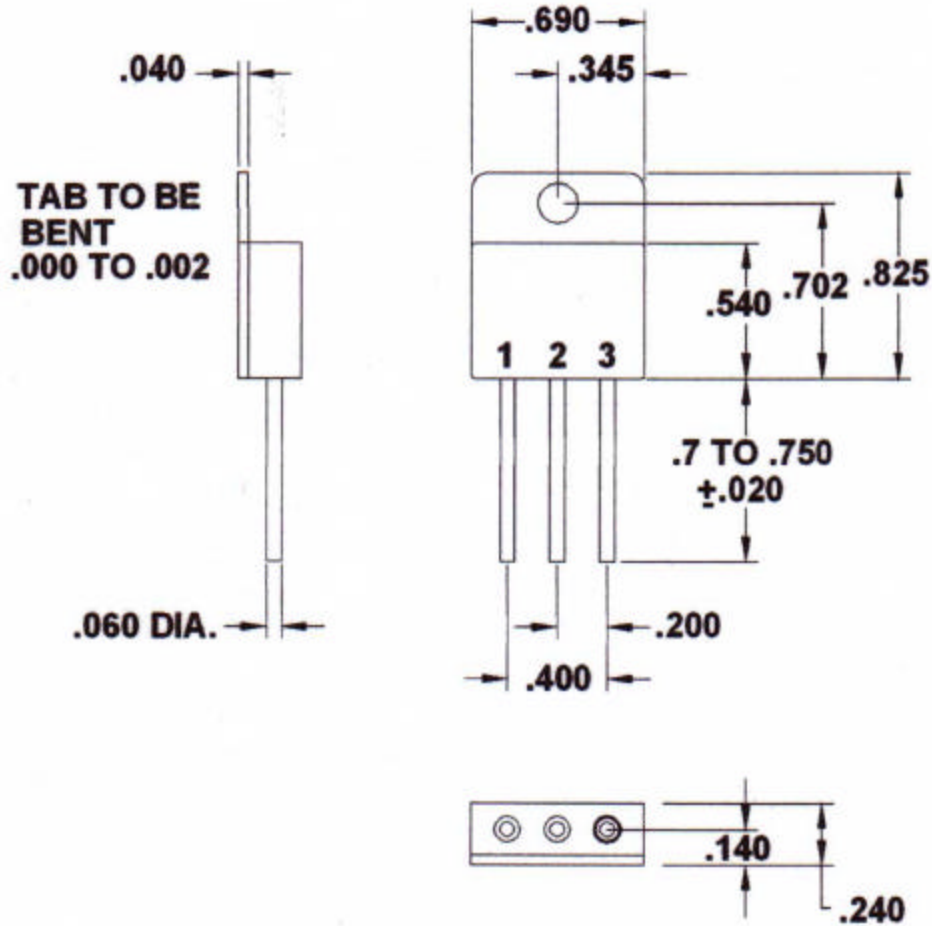

* ALL DIMENSIONS IN INCHES

Pin	Function
1	V _{OUT}
2	Common
3	V _{IN}

Micropac Industries cannot assume any responsibility for any circuits shown or represent that they are free from patent infringement. Micropac reserves the right to make changes at any time in order to improve design and to supply the best product possible.