

53259**POWER MOSFET OPTOCOUPLER
SPST NORMALLY CLOSED****Mii**

MICROCIRCUITS DIVISION

Features:

- Hermetically Sealed 8-Pin Dual-In-Line package
- Normally Closed Contact
- Performance over -55°C to $+125^{\circ}\text{C}$ Ambient Temperature Range
- ± 400 VDC Blocking Voltage in Bi-directional Mode
- AC/DC Switching
- Maximum AC / DC Load Current: 0.12 A / 0.24 A
- 1500 VDC Withstand Test Voltage
- Optically Isolated
- 1.5 A Output Surge Current
- Same foot print as HSSR 7111 / Mii 53111

Applications:

- Satellite / Space Systems
- Military / High Reliability Systems
- Power Distribution Control
- AC/DC Electromechanical or Reed Relay Replacement
- I/O Modules for Automated Test Equipment
- Process Control
- Telecom Applications
- Medical Electronics

DESCRIPTION

The 53259 is a single channel power MOSFET optocoupler. Low on-resistance of the MOSFET outputs, combined with 1500 VDC isolation between input and output, makes this optocoupler ideal for many solid state relay applications. Operation is specified over the full military temperature range. The part is supplied in an eight-pin, dual-in-line ceramic package, available in variety of quality levels from COTS to class K including any custom screening requirements. The basic data sheet part is environmentally screened to H level in accordance with Table C-IX of MIL-PRF-38534. For ordering part number; consult with Micropac factory for detail. The part is normally shipped with gold plated leads, but lead finishes per MIL-PRF-38534 are available.

Functionally, the device operates as a single-pole, normally closed (1 Form B) solid state relay. The device is actuated by an input current, which can be supplied from standard logic types such as open-collector TTL. The input current biases a light emitting diode that is optically coupled to an integrated photovoltaic diode array. The photovoltaic array powers control circuitry that operates the output MOSFETs.

Optimum switching of either AC or DC loads is provided by a configurable output. For AC loads, connection A in Figure 1 must be used. Connection A will also switch DC loads but connection B, in Figure 1, provides DC-only operation with the advantages of substantial reduction in on-resistance and twice the output current capability as that obtained with connection A.

Micropac Industries cannot assume any responsibility for any circuits shown or represent that they are free from patent infringement. Micropac reserves the right to make changes at any time in order to improve design and to supply the best product possible.

ABSOLUTE MAXIMUM RATINGS

Storage Temperature Range	-65°C to +150°C
Operating Ambient Temperature - T_A	-55°C to +125°C
Junction Temperature - T_J	150°C
Lead Solder Temperature (1.6mm below seating plane for 10 seconds)	260°C
Average Input Current - I_F	20 mA
Peak Repetitive Input Current - I_{Fpk} (Pulse Width < 100ms; duty cycle < 50%)	40 mA
Peak Surge Input Current - I_{Fpk} surge (Pulse Width < 0.2ms; duty cycle < 0.1%)	100 mA
Reverse Input Voltage - V_R	5 V
Output Current	
Connection A - I_O	0.12 A
Connection B - I_O	0.24 A
Inrush Output Current	
Connection A - I_{Opk} surge	1.5 A
Output Blocking Voltage	
Connection A - V_O	± 400 VDC
Connection B - V_O	0 V to +400 VDC
Output Power Dissipation	500 mW

RECOMMENDED OPERATING CONDITIONS:

PARAMETER	SYMBOL	MIN	MAX	UNITS
Input Current (off)	$I_{F(OFF)}$	5	20	mA
Input Voltage (on)	$V_{F(ON)}$	0	0.6	VDC
Operating Temperature	T_A	-55	+125	°C

Note: On state means contact closed. Off state means contact open.

Micropac Industries cannot assume any responsibility for any circuits shown or represent that they are free from patent infringement.
Micropac reserves the right to make changes at any time in order to improve design and to supply the best product possible.

ELECTRICAL SPECIFICATIONS

$T_A = -55^\circ\text{C}$ to $+125^\circ\text{C}$, unless otherwise specified.

Parameter	Sym.	Min.	Typ.*	Max.	Units	Test Conditions	Notes
Output Blocking Voltage	$ V_{O(OFF)} $	400	----	----	V	$I_F = 10\text{ mA}$ $I_O = 10\text{ }\mu\text{A}$	
Output On-Resistance (Connection A)	$R_{(ON)}$	----	25	50	Ω	$I_F = 0\text{ mA}$ $I_O = 120\text{ mA}$ (pulse duration $\leq 30\text{ ms}$)	2 Figure 3
Output On-Resistance (Connection B)		----	12	25	Ω	$I_F = 0\text{ mA}$ $I_O = 240\text{ mA}$ (pulse duration $\leq 30\text{ ms}$)	
Output Leakage Current	$I_{O(OFF)}$	----	0.2	10	μA	$V_{O(OFF)} = 400\text{ V}$	
Input Forward Voltage	V_F	1.0	1.2	1.9	V	$I_F = 10\text{ mA}$	
Input Reverse Breakdown Voltage	V_R	5.0	12	----	V	$I_R = 10\text{ }\mu\text{A}$	
Input-Output Insulation	I_{I-O}	----	----	1.0	μA	$RH \leq 45\%$, $t = 5\text{ s}$ $V_{I-O} = 1500\text{ VDC}$ $T_A = 25^\circ\text{C}$	3, 4
Turn-On Time	t_{ON}	----	0.3	3.0	ms	$I_F = 0\text{ mA}$ $I_O = 120\text{ mA}$	Figure 3
Turn-Off time	t_{OFF}	----	0.1	1.0	ms	$I_F = 10\text{ mA}$ $I_O = 120\text{ mA}$	Figure 3

* All typical values are at $T_A = 25^\circ\text{C}$, unless otherwise specified.

Notes:

1. Maximum junction to case thermal resistance (θ_{JC}) for the device is 15°C/W , where case temperature (T_C), is measured at the center of the package bottom.
2. During the pulsed $R_{(ON)}$ measurement (I_O duration $< 30\text{ ms}$), ambient (T_A) and case temperature (T_C) are equal.
3. Pins 2 through 3 shorted together and pins 5 through 8 shorted together.
4. This is a momentary withstand test, not an operating condition.
5. Care should be taken not to exceed the maximum output power dissipation, maximum case temperature, and maximum junction temperature when repetitively switching loads.

Micropac Industries cannot assume any responsibility for any circuits shown or represent that they are free from patent infringement. Micropac reserves the right to make changes at any time in order to improve design and to supply the best product possible.

Terminal number	Terminal symbol	
	Connection A (AC or DC load)	Conneciton B (DC load only)
1	NC	NC
2	V_{F+}	V_{F+}
3	V_{F-}	V_{F-}
4	NC	NC
5	V_{O-}	V_{O+}
6	NC	V_{O-}
7	NC	V_{O-}
8	V_{O+}	V_{O+}

NC = No connection

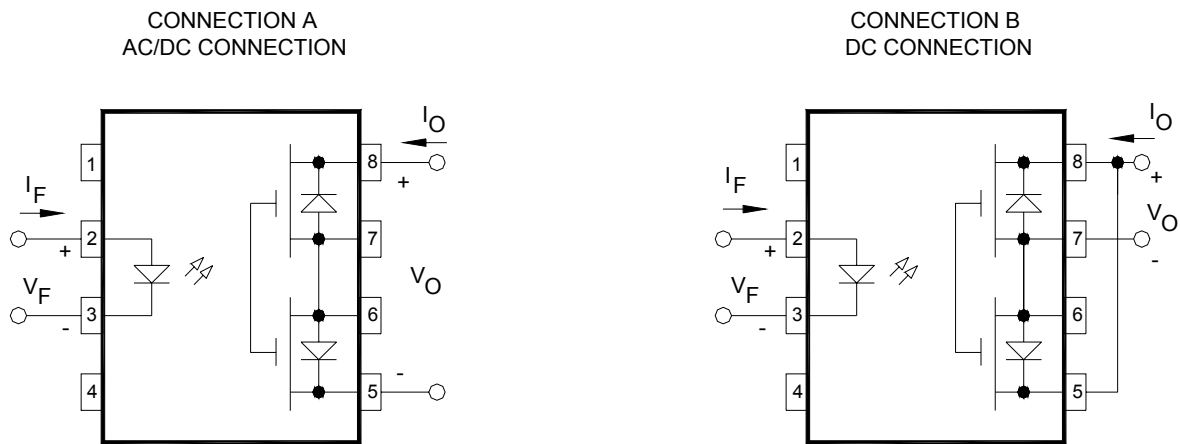
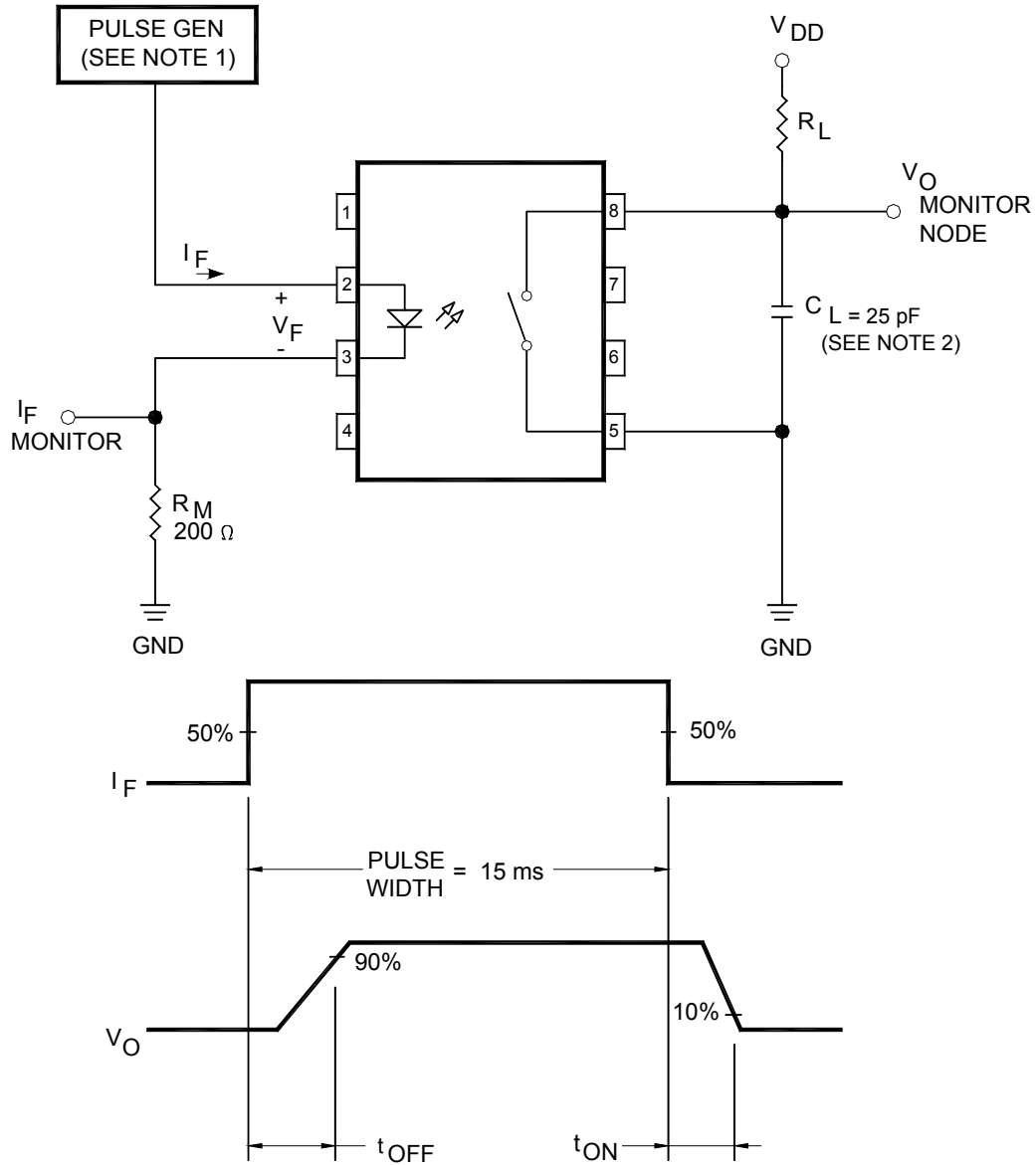

Figure 1. Terminal Connections

INPUT	OUTPUT
OFF	ON
ON	OFF

Figure 2. True Table

Micropac Industries cannot assume any responsibility for any circuits shown or represent that they are free from patent infringement. Micropac reserves the right to make changes at any time in order to improve design and to supply the best product possible.



NOTES:

1. PULSE GENERATOR HAS THE FOLLOWING CHARACTERISTICS: OUTPUT IMPEDANCE = 50 Ω AND $t_r = t_f = 5.0 \text{ ns}$.
2. LOAD CAPACITANCE (C_L) INCLUDES PROBE AND JIG CAPACITANCE.

Figure 3. Switching Test Circuit and Waveform.

Micropac Industries cannot assume any responsibility for any circuits shown or represent that they are free from patent infringement. Micropac reserves the right to make changes at any time in order to improve design and to supply the best product possible.

Case Outlines

CASE OUTLINE P

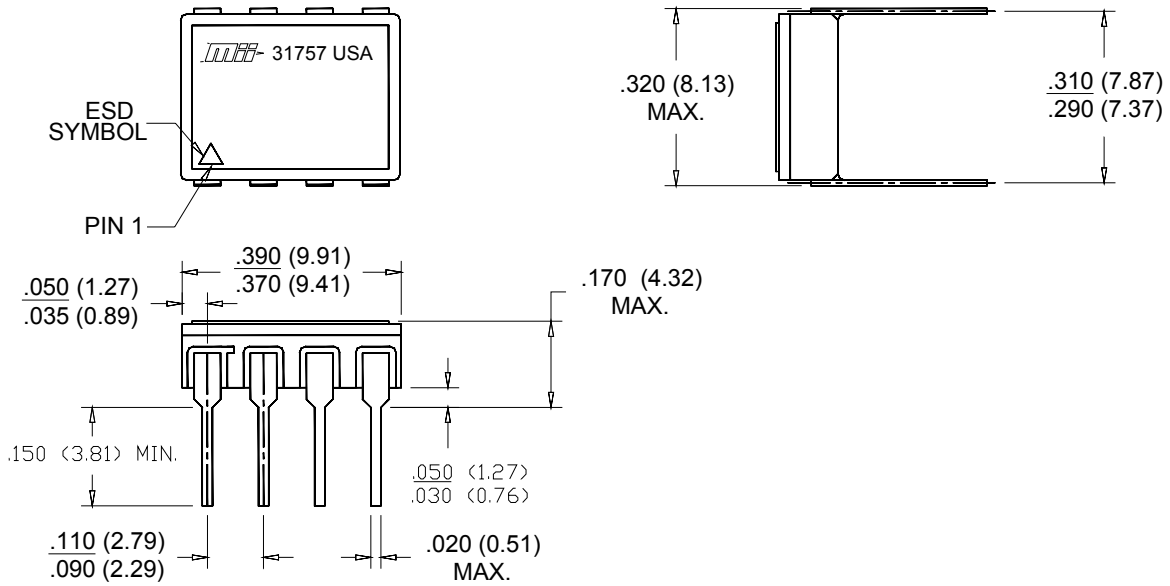

CASE OUTLINE X

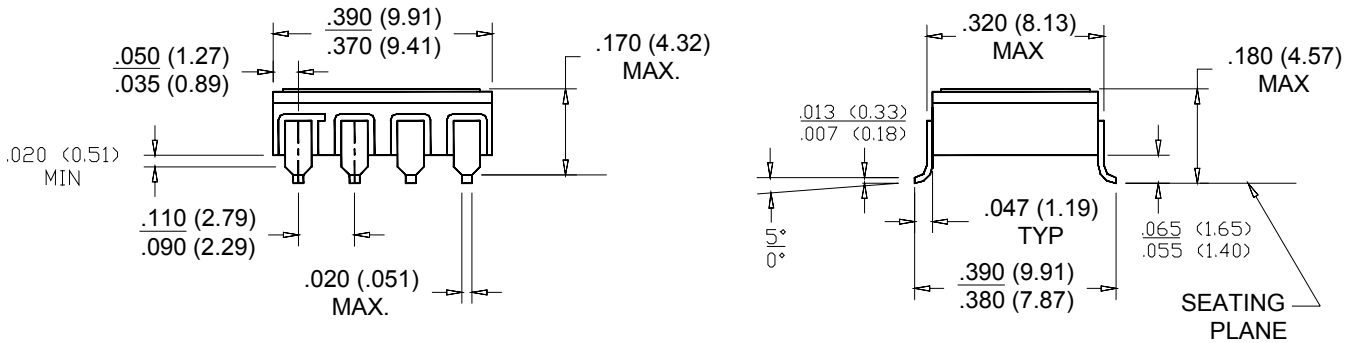

NOTES:

1. PIN 1 IS INDICATED BY THE ESD TRIANGLE MARKED ON THE LID OF THE PACKAGE.
2. DIMENSIONS ARE IN INCHES, (mm).
3. METRIC EQUIVALENTS ARE GIVEN FOR GENERAL INFORMATION ONLY.
4. UNLESS OTHERWISE SPECIFIED, TOLERANCE IS ±.005 (0.13mm).

Micropac Industries cannot assume any responsibility for any circuits shown or represent that they are free from patent infringement. Micropac reserves the right to make changes at any time in order to improve design and to supply the best product possible.

Ordering Guide

The following chart explains the ordering procedure for Micropac Part Numbers.
Please contact Micropac for other desired options.

Example: Mii P/N 53259-PA

<u>53259-</u>	P	A	
Device Type & Model Number	<u>Case Outline</u>	<u>Lead Finish</u>	<u>Quality Screening Level</u>
	P: 8-Pin DIP X: 8-Pin Gull Wing	A: Solder DIP C: Gold Plate X: Either A or C	None: Per Data Sheet It is screened IAW Table C-IX of MIL-PRF-38534, Level H K: Class K, MIL-PRF-38534

Micropac Industries cannot assume any responsibility for any circuits shown or represent that they are free from patent infringement.
Micropac reserves the right to make changes at any time in order to improve design and to supply the best product possible.